

**CENTA** POWER TRANSMISSION  
LEADING BY INNOVATION



# GENERAL PACKING SPECIFICATION

ENGLISH  
VV-01-01-15 - REV. 1 - MAR 2016

# GENERAL CENTA PACKING SPECIFICATION



## CONTENTS

	Page
Contents	
1 Object and aim of the general packing specification	3
2 General specifications	3
3 Permissible carriers	3
4 Special requirements for wooden packing material	3
5 Transport & corrosion prevention	4
5.1 Filling materials	4
5.2 Restricted materials	4
5.3 Corrosion protection of the goods	4
5.4 Anticorrosive packing	5
6 Handling and correct use of carriers	5
7 Implementation of load units	6
7.1 Loading	6
7.2 Stackability	6
7.3 Load securing	6
8 Stacked material	7
9 Loose material in bulk	7
10 Bundled material	7
11 Technical condition of packing	7
12 Exchangeability of loading equipment	7
12.1 Samples for non-exchangeable Euro-Paletts	7
12.2 Samples for non-exchangeable stacking frames	8
12.3 Samples for non-exchangeable pallet cages	8
13 Completeness of accompanying documents	8
14 Accompanying documents	9
14.1 Delivery Note	9
14.2 Bill of lading	9
14.3 Packing list	9
14.4 Identification	9
14.5 Identification of single packages	9
15 Environment Management	10
16 Handling of faulty packing	10
APPENDIX	11

# GENERAL CENTA PACKING SPECIFICATION



## 1 OBJECT AND AIM OF THE GENERAL PACKING SPECIFICATION

The packing specification applies to all parts and components being delivered to CENTA Antriebe Kirschey GmbH (CENTA) and is practical guideline for the optimization of increasing material flow and transport with other companies.

Primary aim of the general CENTA packing specification is the short termed flow of the delivered materials faultless and without additional work by repacking, or new labeling of goods into our stock systems. The adherence to regulations by law or contract is sole responsibility of the supplier.

Upon nonconformity with the general specifications, the supplier is given the possibility for rectification within an individually set time limit. Should this limit be exceeded, CENTA will charge the supplier with the correction needed by reducing the relevant invoice by the expenses. Invoice terms (sconti) will be intermitted for the period of reclamation.

The compliance with this packing specification is part of the supplier evaluation. Noncompliance will have negative effect on the supplier evaluation (see appendix).

Deviations of this packing specification are subject to prior written approval by CENTA and are to be specially mentioned on the delivery note and on the single package/es.

Following standards are going to be implemented:

- Standardised load carriers or packaging aids
- Standardised marking/labeling
- Standardised accompanying documents

## 2 GENERAL SPECIFICATIONS

Following specifications for packing have to be met:

The packing chosen has to comply to the requirements of the goods to be packed (§§ 40 ff. HGB). It has to withstand the strain of the intended kind of transport.

The way and medium of transport as well as possible influences such as weather conditions and the handling upon re- or transloading have to be taken into consideration.

Following are to be considered:

- kind and condition of the planned route
- expected influences on the goods during transport
- climate conditions
- no impurity
- sufficient guard of the packing upon stowage, reloading or other movement of the goods.

## 3 PERMISSIBLE CARRIERS

Deliveries may only be made in the following mentioned load carriers:

- Europaletts acc. DIN 15146-part 2 (max. gross weight 500 kg)
- Palett cages acc. DIN 15155 (max. gross weight 1000 kg)
- Single packages (f.e. nonreturnable cardboard boxes being moved by hand)
- CENTA KLT black

In order to keep risk of injury for personell of CENTA and the supplier low, a maximum gross weight of 30 kg for single packages may not be exceeded.

Single packages with more than 30 kg have to be delivered on relevant load carriers (min. 100 mm underriding height).

Nonreturnable paletts are only accepted in exceptional cases and require prior approval.

## 4 SPECIAL REQUIREMENTS FOR WOODEN PACKING MATERIAL

For all wooden packing material, the adherence to IPPC- und ISPM-standards is obligatory. Materials used must be untreated. Impregnation, primering and coatings are inadmissible.

The use of ply wood (flake wood or fiberboard) are admissible, if the given packing specifications and requirements are met.



## 5 TRANSPORT AND CORROSION PROTECTION

### 5.1 Filling materials

Only filling material made of soda kraft paper (Natron Misch 80g), VCI paper or Branorost paper may be used. Only new and faultless packing material may be used. The wrapping materials may not influence the cleanness of the goods.

The use of print media (f.e. news papers or similar) and styrofoam chips is not admissible.

### 5.2 Restricted Materials

The maximum permissible values for forbidden materials according EU-General Packing Specification (94/62/EG) are obligatory.

### 5.3 Corrosion protection of the goods

A sufficient corrosion protection of the components is to be aimed at during production processes, storage and transport. For parts subject to obligatory corrosion protection the transport bins have to be free of residues. Excessive use of corrosion protection shall be avoided. Corrosion material may not be applied to the parts exceedingly.

- No conducive application, no drop formation
- Upon packing, attention has to be taken that no humid, hot or warm parts are packed.
- In addition the packing at high humidity (more than 95% or less than 23%) shall be avoided.
- After customs clearance or sampling the packing has to be reclosed tight and clean.
- Damage to the corrosion protecting packing (f.e. holes or scissures) that might occur during transport, loading and reloading as well as general handling shall be avoided.
- CENTA regulations for corrosion protection have to be adhered to by the supplier.

Any corrosion sensitive parts, as well as all machined or ground surfaces, specially on cast or forged parts, are subject to special protection and have to be adequately treated against corrosion. The conservation time of the corrosion protection has to be guaranteed for at least 12 months.

Preventive conservation methods are corrosion protection of material and suitable packing.

CENTA only allows the use of preserving agent **Dewatering Fluid 48**, if not agreed on others. Dewatering is a multifunctional preserving agent, free from aromatic compounds and water displacing which is specially suitable for high corrosion prevention on metal parts. Depending on viscosity it can be applied by brush, spraying, whipping or immersion and forms a thin, soft and waxy protective film. To guarantee the protecting properties a film thickness of ca. 4–7 µm is adequate. This can easily be removed by use of suitable cleaners, if necessary.

Metal finished parts have to be clean and free of finger prints and should be conserved directly after machining. To avoid finger prints gloves should be used.

Absorbant plating and anticorrosion lining f.e. crinkled cardboard, foam film, foam plates or felt are not permissible.

Coated surfaces of finished parts are not to be conserved.

Nevertheless a partial corrosion protection shall be applied on unprotected areas of these parts (tap holes, seal faces etc.). This protection has to be removable in common production circumstances and temperatures.

The following pictures show a sample for anticorrosive packing:

# GENERAL CENTA PACKING SPECIFICATION



## step 1



empty pallet cage

## step 2



pallet cage with plastic lining

## step 3



pallet cage with side gusseted bonnet

## step 4



place plastic lining on the cage bottom

## step 5



place Branorost paper on the new plastic lining

## step 6



place soda kraft paper Natron Misch 80 g or Branorost 80 g for material padding

## step 7



repeat a layer of Branorost paper onto the material

## step 8



repeat a layer of plastic lining

## step 9

repeat steps 5-8 until the pallet cage is filled

## step 10

close the VCI gusseted bonnet

## 5.4 Anticorrosive packing

Independent of applied corrosion protection on the material, parts have to be delivered protected against corrosive agents and surface damage during transport and storage.

If necessary, anticorrosion foils have to be used, f.e. VCI-foil or paper which can be recycled in regular ways.

The chosen anticorrosion packing may not have effect on the function or appearance of the parts.

Before despatch to CENTA it has to be assured, that all corrosion sensitive parts are adequately conserved, wrapped, sealed or packed. Delivered parts without the corrosion protection agreed upon are faulty and will be rejected.

## 5 HANDLING AND CORRECT USE OF CARRIERS

Independent of the packing choice, following requirements have to be met:

- free of dirt and impurity
- poolability
- stackability
- underriding ability
- Use of aids (f.e. edge protection) is recommended
- Goods may not protrude the side edges of Europaletts. The use of specific packing is recommended. The choice of packing is subject to specifications of the goods, securing requirements, kind of transport and the circumstances at suppliers premises.
- Even load spread on the load carriers
- Identification of the used packing materials
- Recyclable materials.



# GENERAL CENTA PACKING SPECIFICATION



## 7 IMPLEMENTATION OF LOAD UNITS

Unit handling, stacking and storage must be possible upon use of load units.

If small containers set one load unit, they have to meet the standard dimensions of paletts.

Different goods may be commissioned as a load unit correctly sorted beside each other and visibly divided by layers (unstacked).

Similar articles may not be within the same load unit to avoid mistakes and erroneous entry.

## 7.3 Load securing

The choice of packing should always ensure load securing. The use of shrink hoods, straps or stretch foils will avoid sliding or damage of the goods upon transport.

- Use of edge protections on cardboard boxes will avoid cutting of the packing
- Use of wooden stacking frames secure stacked goods from sliding
- The technically perfect condition of the stacking frames has to be ensured by the supplier
- Upon removal of partial quantities of the load unit, stability of the remaining packs has to be ensured
- Enough space between the palett-bottom has to be ensured for the use of floor-borne vehicles with automatic conveyance
- Load unit securing may not cause disturbance

### 7.1 Loading

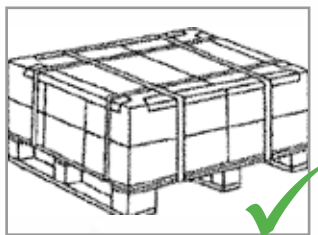
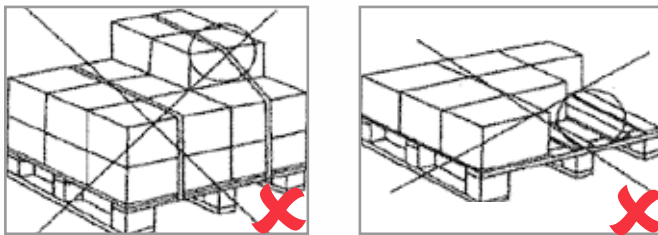

### 7.2 Stackability

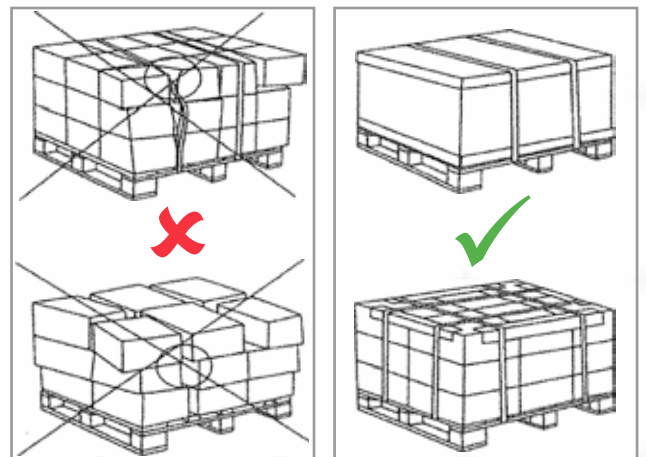
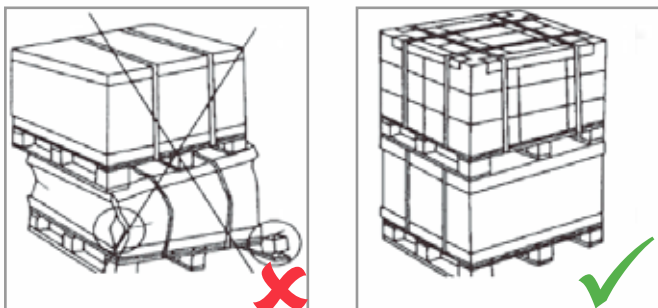

# GENERAL CENTA PACKING SPECIFICATION



## 8 STACKED MATERIAL

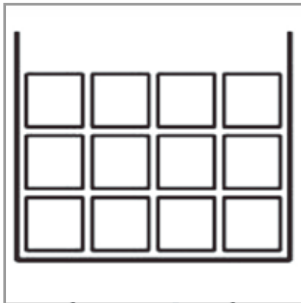

Stacked material has to be stapled in the packing thus avoiding movement or sliding of the contents during handling and transport.

## 11 TECHNICAL CONDITION OF PACKING

To meet the quality requirements of supply, the following have to be adhered to:

- The parts have to be free of dirt
- The parts have to be protected from mechanical damage and corrosion by the use of adequate packing
- Sufficient securing of packing and load units upon transport and handling has to be ensured. Adequate possibilities for load securing have to be considered, f.e. belt eyes or fishing plates)

## 9 LOOSE MATERIAL IN BULK



Loose material parts with sensitive surfaces (f.e. sealed face, spline or fitting) are easily damaged by pressure load and may not be delivered as loose materials in bulks.

## 12 EXCHANGEABILITY OF LOADING EQUIPMENT

Flawless condition of Europaletts has to be ensured according the exchangeability specifications of the European Pallet Association EPAL.

## 10 BUNDLED MATERIAL

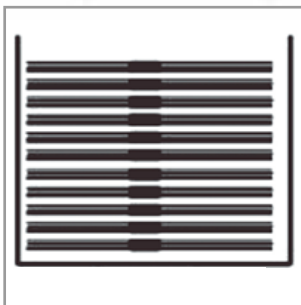

Bundled material has to be correctly sorted and secured against sliding. To avoid bending of cut goods (f.e. tubes) during transport, the goods have to be secured by timber beams. To enable proper handling of lifting devices, the bundles

have to be strapped or shimmed with rectangular timber beams.

Protection caps have to be applied to the openings of tubes for transport.

### 12.1 Samples for non-exchangeable Europaletts

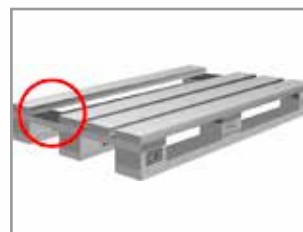

One plank is missing.



One plank is broken abeam or diagonal. More than two planks and/or edge decking planks are splintered.



One floorboard or edge decking plank is splintered.

# GENERAL CENTA PACKING SPECIFICATION



One block is missing or split.

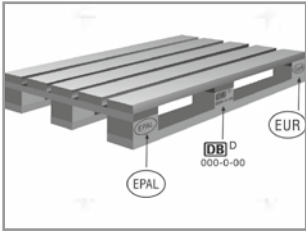

Bad general condition, f.e. brittle material, strong splitting. Unallowable elements i.e. thin planks or slim beams. Missing DB/EUR stamps.

## 12.2 Samples for non-exchangeable stacking frames



The dowel pins are turned, leading to improper fit in the frame and the load securing is not assured.



The connecting edges are separated from the wood. Load securing is no longer possible.



The frame joints are bended in a way that flush stacking of the frames is no longer possible.

## 12.3 Samples for non-exchangeable palett cages



One plank is missing or split. The floor frame is bent in a way hindering the palett cage standing on its four feet evenly and can not be stacked without danger.



The folding square or the edge pillars are deformed.



The round steel grid bars are ripped so the wire ends are bent in- or outwards.

## 13 COMPLETENESS OF ACCOMPANYING DOCUMENTS

Deliveries are complete if beside the goods following necessary accompanying documents are available:

- Delivery note
- Bill of lading
- Packing list (when indicated with parts list)
- Product accompanying documents f.e. certificates, declaration of compliance or specifications.



# GENERAL CENTA PACKING SPECIFICATION



## 14 ACCOMPANYING DOCUMENTS

### 14.1 Delivery Note

The delivery note should comply to DIN 4991 and include following data fields.

- Number and date of the delivery note
- Place of delivery
- CENTA order number, scheduler at CENTA
- Order position number (if more than one position are on one order)
- CENTA part number
- Material identification
- Delivered quantity
- Gross weight incl. measuring unit
- Kind and quantity of single load carriers/packings (Europaletts, disposable cardboard boxes, disposable paletts etc.)
- Material batch lot
- Mode of despatch (f.e. truck, courier etc.)
- Despatch terms (f.e. CIP, FCA)
- Name of freight carrier/forwarding agent
- Name and adress of the supplier, including contact data for questions
- Special remarks, f.e. expiry or production date according the order for parts with limited use, eccentric load, notice of special agreements.

### 14.2 Bill of lading

The supplier has to provide the load carrier/forwarding agent with one bill of lading for each place of lading.

Specific features such as eccentric load or missing/limited stackability have to be indicated.

- To ensure tracability the bills of loading have to carry the delivery note number
- Delivery notes have to be adhered to the relevant bill of loading. Both are to be handed over to the freight carrier.
- A visible and protected further copy of the delivery note has to be tacked to the load carrier/single pack.
- A bill of lading is unnecessary upon selfmade deliveries.

### 14.3 Packing list

Should a delivery consist of more than one pack or palett/palett cage, a packlist with following order information has to be attached:

- Number and quantity of the packs, paletts/palett cages
- CENTA part number
- Quantity of parts
- Quantity and content of the single packs.

These information also have to be visible on the single packings. The content of single packings has to correspond to the labeling.

### 14.4 Identification

Identification has to be attached visibly on the side of a load carrier resp. packing.

The attachment to the boxes or palett cages has to be done with a removable glue to avoid cleaning work due to residues.

### 14.5 Identification of single packages

All packing units and their contents have to be labeled seperately. The labeling also has to be mentioned on the delivery note. CENTA article numbers are always mentioned together with the order.

If not otherwise agreed upon, the permissible delivery adress is:

CENTA Antriebe  
Kirschey GmbH  
Bergische Strasse 7 →→ 42781 Haan  
access by:  
Eifelstrasse 5  
42781 Haan

Contact at receiving department:  
Mr. Sebastian Olszewski, Mr. Lucien Dutz  
phone +49 2129-912-215  
wareneingang@centa.de

receiving times:  
Monday–Thursday: 7:00–15:30 hrs  
Friday: 7:00–14:00 hrs

break/lunchtimes: 09:30–09:45 hrs  
11:45–12:00 hrs



## **15 ENVIRONMENT MANAGEMENT**

Ecological thinking is natural to us and is one of the main integral parts of our entrepreneurial responsibility. We dispose of old packing materials ecologically and according to local and state regulations.

## **16 HANDLING OF FAULTY PACKING**

The goods have to be faultlessly delivered as specified in kind, quantity and quality. This also applies to proper packing.

Should faulty packing be noticed upon delivery, CENTA reserves the right to reject the goods completely or accept them under reserve. The occurring expenses for additional work will be charged to the supplier.

The right for rejection and the right to invoice additional work also applies to invisible faults being found at a later time of the receipt processes.

# GENERAL CENTA PACKING SPECIFICATION

## APPENDIX

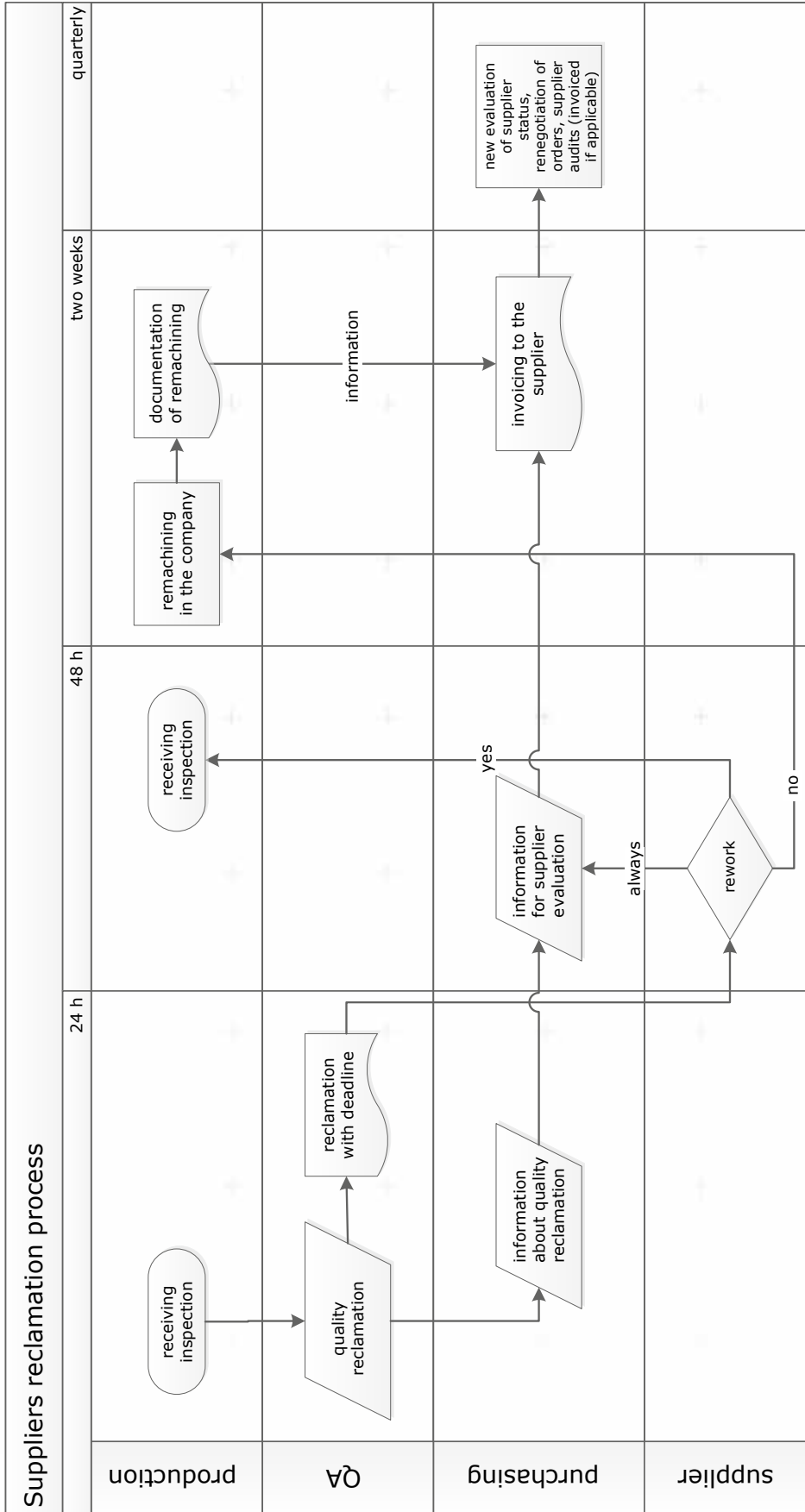

CENTA is the leading producer of flexible couplings for industrial, marine and power generating applications. Worldwide.

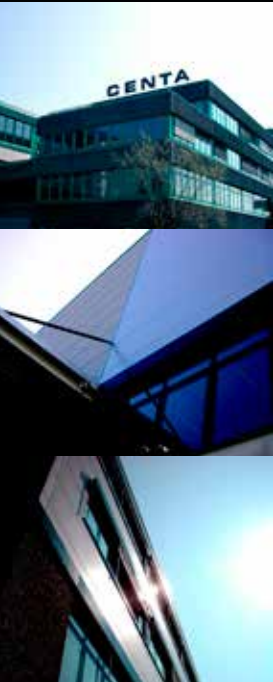

[WWW.CENTA.INFO/CONTACT](http://WWW.CENTA.INFO/CONTACT)

**HEAD OFFICE**

CENTA Antriebe  
Kirschey GmbH

Bergische Strasse 7  
42781 Haan/Germany

+49-2129-912-0 Phone  
+49-2129-2790 Fax

info@centa.de  
www.centa.info